

PARTS CHART
FOR
SINGER^{*}
990_{E3} 990_{E43}
MACHINES

From the library of: Diamond Needle Corp

PART No.	DESCRIPTION	LOCATION
10875	Wrench (flat)	K5
17022	Thread (looper right hand) Take-up Screw Washer	H7
20822	Looper (right hand) Carrier Connecting Link Adjusting Sleeve Wick Clip	E6
23250	Treadle Hinge Bracket Bolt Washer	L8
39541	Cloth Plate Hinge Stud Washer	A6
42436	Presser Bar (swing-out) Opening Lever Hinge Screw Washer	C4
42436	Knife (movable) Lever and Presser Bar (upright) Housing Cover Stop Plate Screw Washer (2)	D3
49109	Earthing Wire Washer	M7
50073(809)	Knife (movable) Lever and Presser Bar (upright) Housing Screw (2)	C4, B4
50073(809)	Machine Frame Top Cover Screw (2)	F2, E2
50169(809)	Presser Foot Guide Screw	—
50225(809)	Presser Foot Clamping Plate Screw	—
50225(809)	Needle Guard Screw	—
50318(818)	Thread (looper) Plate Thread Bushing Screw	C7
50611(805)	Knife (stationary) and Needle Guard Holder Position Screw	H7
51082-002	Treadle Hinge Bracket Bolt 141223-002 with 51581	C7
51089	Treadle Position Collar Bolt	—
51224(818)	Chain Cutter Knife Holder and Feed Bar Guide Cover Securing Screw	L8
51306(805)	Presser Foot Chain Cutter Knife Screw	L2
51362(830)	Presser Bar (swing-out) Pivot Locking Plate Screw	—
51369(819)	Feed Eccentric Cover Hinge Bracket Screw (2)	C5
51423(850)	Presser Bar Lifting Lever (long) Hinge Stud	A8
51581	Treadle Position Collar Bolt Nut	A4
51723	Treadle Extension Wing Nut	K8
51768(803)	Needle Clamping Nut	K8
51797	Machine Base Mounting Screw Insert (4)	D5
51846	Presser Bar Lifting Bracket Roller and Stud	L6
59456	Looper (left hand) Carrier Washer	C4
67425	Treadle Extension Wing Nut Lock Washer	G6
81202(813)	Feed Eccentric Oil Cover	K8
81231	Machine Cushion (large)	A7
81350-011	Tin of Oil (500 ml, Type H)	K6
81425-001	Throat Plate (standard for NAIMO)	L5
81433	Throat Plate Guide with 853(830)	—
81440	Wrench (short) for 1/16 in Socket Head Screw	C7
82253	Gauge	L5
82281	Thread Eyelet (needle thread)	L8
82309	Needle Stop Pin	D4
82312	Needle Holder	D5
82313	Needle Holder Washer	D5
82330(850)	Presser Bar (swing-out)	D5
87027	Looper (right hand)	C6
87029	Knife (movable) Lever Bearing and Attachment Bracket	E6
87262	Knife (movable) Lever Bearing and Attachment Bracket with 1259(803)	D5
90100	Oil Pipe Retaining Clip	D5
98188	Tension Thread Guide Securing Nut Washer	E4, E6
98188	Presser Bar Lifter Operating Arm Bracket Bolt Washer	E2
98930	Machine Frame Rotary Shaft Ball Sleeve Guide	M8
101896	Thread (looper right hand) Tube (lower)	—
101970	Looper (right hand) Position Collar	H6
106132	Knife (movable) Holder	F6
106144	Presser Bar Lifting Bracket	D6
106401	Oil Reservoir Oil Sight Gauge Seal (O-Ring)	C4
106430	Belt Cover	E8
106442	Feed (back) Bar Connection	H1
106445-014	Feed (front) Eccentric (106445-006 to 106445-036 available to order)	B7
106445-014	Feed (back) Eccentric (106445-006 to 106445-036 available to order)	A7, B7
106447	Feed (front) Bar Connection	A7, B7
106448	Feed (back) and (front) Bars complete Nos. 106442, 106447, 164006, 165135, 164018, 164687, 107160, two each 1718(803), 9525(803), 164004 and 164009	B7
106450	Feed Eccentric Cover Hinge Bracket	B7
106456(696)	Knife (movable) Lever and Presser Bar (upright) Housing with 460	A8
106457	Knife (movable) Lever and Presser Bar (upright) Housing complete Nos. 106456(696), 114082, 42436, 106144, 107080, 114159, 114275(888), 164139, 107081, 164143(850), 164416 and 82281	C4
106461	Knife (movable) Lever and Presser Bar (upright) Housing Cover Latch Spring	D4
106462	Knife (movable) Lever and Presser Bar (upright) Housing Cover Latch Spring Pin	E3
106464	Knife (movable) Lever Guide	E4
106466	Knife (movable) Lever Hinge Stud	D5
106471	Knife (stationary) and Needle Guard Holder Sleeve Stud	C8
106472	Knife (stationary) and Needle Guard Holder Sleeve	D7
106473	Looper (left hand)	D6
106476	Looper (left hand) Driving Shaft Access Hole Plug	G6
106476	Looper (right hand) Driving Shaft Access Hole Plug	—
106477	Looper (left hand) Driving Shaft Bushing (back)	—
		D5, E5

PART No.	DESCRIPTION	LOCATION
106477	Looper (right hand) Driving Shaft Bushing (back)	D5, E5
106478	Looper (left hand) Driving Shaft Bushing (front)	E5
106487	Looper (right hand) Carrier Connecting Link Adjusting Sleeve Wick Seal	E6
106492	Looper (right hand) Driving Shaft Bushing (front)	E5
106494	Looper (right hand) Driving Shaft Oil Wick	F6
106496	Looper (right hand) Four-bar Linkage Mechanism Stabiliser	F5
106497	Looper (right hand) Four-bar Linkage Mechanism Stabiliser 106496 with 106498 and two 350680	F5
106498	Looper (right hand) Four-bar Linkage Mechanism Stabiliser Support Bracket	F5
106500	Machine Frame Bracket Assembly with 107024 and 187(805)	—
107024	Machine Frame Bracket Key	—
107025	Machine Frame Closing Plate	E6
107028	Machine Frame Oil Plug Bracket	C7
107029	Machine Frame Oil Pressure Gauge Connection Plug	G5
107033	Machine Frame Rotary Shaft Ball Bearing Housing	J3
107034	Machine Frame Rotary Shaft Ball Bearing Housing Gasket	J3
107037	Machine Frame Rotary Shaft Oil Metering Pin	—
107038	Machine Frame Rotary Shaft Plug	D5
107044	Machine Frame Top Cover Closing Plate Gasket	E4
107045	Machine Pulley with two 448(830)	H2
107046	Machine Pulley Cap	J1
107055	Needle Driving Shaft Crank Connection Roller (27)	—
107065	Oil Pump Drive Pin	F5
107066	Oil Pump Rotor (inner)	G4
107067	Oil Pump Rotor (outer)	G4
107071	Oil Reservoir Oil Sight Gauge	F8
107075	Oil Pump Relief Valve	E4
107076	Oil Pump Relief Valve Body	E4
107077	Oil Pump Relief Valve Plunger	E4
107078	Oil Pump Relief Valve Spring	E4
107079	Oil Pump Relief Valve complete Nos. 107075, 107077, 107078, 114081 107076 and 113179	E4
107080	Presser Bar Lifting Lever	A3
107081	Presser Bar (swing-out) Opening Lever	C4
107082	Presser Foot Body (for 107083)	—
107083	Presser Foot complete 50169(809), 107082, 50225(809), 164146, 164147, 164149 (standard except NAIMO)	C6
107084	Tension (heavy) Spring	E1
107085(429)	Tension (heavy) complete (green) Nos. 107178, 107625, 107084, 113180(429), 113191(888), 114117(803) and two 2102	F1
107085(431)	Tension (heavy) complete (red) Nos. 107178, 107625, 107084, 113180(431), 113191(888), 114117(803) and two 2102	F1
107086(430)	Tension (light) complete (yellow) Nos. 107178, 107625, 164157, 113180(430), 113191(888), 114117(803) and two 2102	F1
107090	Looper (left hand) Thread Tube (upper)	E2
107090	Thread (looper right hand) Tube (upper)	E2
107091	Thread (looper) Plate with 462(830)	H7
107092	Thread (looper) Plate complete Nos. 1423(809), 1443(809), 1607(809), 50318(818), 107091, 101896, 164163, 164165, 164173 and 164449	J6
107095	Thread (looper) Plate Cover Hinge Bracket	J8
107096	Thread (looper) Plate Cover Hinge Pin	H8
107097	Thread (looper) Plate Cover Latch Spring	J7
107115	Feed Bar Guide	A7
107158	Machine Frame Oil Pressure Gauge Connection Plug Gasket	G5
107160	Feed (back) Bar Connection Bearing	B7
107161	Presser Bar Bracket	C5
107162	Feed Bar Hinge Pin (eccentric)	A7
107169	Oil Return Filter (front) complete with 107898	E7
107172	Feed Eccentric Cover Latch Spring	B8
107177	Machine Frame Rotary Shaft Ball Bearing Retaining Ring	J3
107178	Tension (heavy) Spring Bushing	E1
107178	Tension (light) Spring Bushing	E1
107185	Feed Lifting Eccentric	B7
107188	Knife (movable) Lever Hinge Pin	C6
107191	Knife (movable) Lifting Lever Retaining Washer	C6
107192	Knife (movable) Lifting Lever Retaining Washer and Oil Sling	C6
107204	Oil Reservoir Drain Plug	E7
107501	Foot Lifter Operating Cable	K7
107502	Treadle Hinge Bracket	L8
107505	Foot Lifter Operating Cable Retaining Collar with 140393	K8
107512	Treadle Hinge Bracket 107502 with two each 23250, 51082-002 and 67425	—
107513	Foot Lifter Operating Cable complete Nos. 107501 and 107505	—
107546	Treadle 115420 with two 107502, four each 23250 and 67425	—
107575	Knife (movable) Lever with two 141292(869)	C5
107620	Thread (needle) Controller	D5
107625	Tension (heavy) Spring Cover	E1
107625	Tension (light) Spring Cover	E1

PART No.	DESCRIPTION	LOCATION
107626	Treadle 115420 with two 107502 and four wood screws 3/4 in No. 12 R. H.	—
107827	Lint Cleaning Brush	K5
107898	Oil Return Filter (front) Screen (upper)	E7
107898	Oil Return Filter (front) Screen (lower)	E7
107935	Oil Pressure Gauge	M7
108026	Machine Frame Rotary Shaft Bushing (front)	D6
108057	Tweezers	K5
108058	Dust Cover	—
108065	Oil Dispenser	L5
108117	Machine Frame Rotary Shaft Plug Sleeve	D5
108123	Belt Cover (rear)	L6
108147	Oil Funnel	L5
108158	Oil Deflector	E6
108205-008	Throat Plate (1/8 in bight) (standard except NAIMO)	C7
108222	Presser Bar Lifter Operating Arm	M8
108224	Earthing Wire	M8
108227	Feed (back) Dog Section (right)	—
108229	Feed (back) Dog complete Nos. 1100(830), 164011 and 108227 (standard except NAIMO)	B6
108300	Machine Frame Top Cover Plug	F2
108330	Thread Eyelet (needle thread) Bridge Tube	D5
108371	Looper (left hand) Thread Tube (lower)	D8
108385	Chain Cutter Knife Holder and Feed Bar Guide Cover	L2
108386	Chain Cutter Knife Holder and Feed Bar Guide	M1
108389	Chain Cutter Knife (movable) Driving Fork with two 109927(869)	M1
108390	Chain Cutter Knife (movable) Driving Slide Block	M1
108391	Chain Cutter Knife (movable) Driving Slide Block Stud	M1
108394	Chain Cutter Knife (movable) Spring	M2
108397	Knife (movable) Lifting Lever	C6
108406	Chain Cutter Suction Pipe (available at an extra charge)	L4
108430	Machine Frame Oil Splash Guard (top)	L1
108441	Chain Cutter Knives Oil Wick	M1
108445	Oil Pump Cover Oil Seal	M3
108452	Wrench (long) for 5/32 in Socket Head Screw	L5
108484	Thread Eyelet (needle thread) Bridge Tube Support with 114235(869)	D5
108495	Chain Cutter Knife (movable) Driving Slide Block Stud Wick	M1
108535	Chain Cutter Suction Pipe Clip (available at an extra charge)	L3
108592	Looper (left hand) Setting Gauge	L8
108597	Chain Cutter Knife (movable) Driving Fork 108390 and 108391	—
108656	Oil Pump Body Clamping Screw Hole Plug Screw Gasket	G5
108670	Presser Bar Lifting Lever (long) Connection Rod Cutter Pin	B4
108671	Presser Bar Lifting Lever (long) Tension Spring	B4
108777	Combination Wrench	K3
108785	Thread Eyelet (needle thread) Bridge	D5
108812	Thread (looper) Take-up	G7
108815	Wrench (socket)	K5
108818	Needle Carrier with 51768(803), 82312 and 82313	D5
108864	Thread (needle) Guide Post Securing Nut Washer	E2
108917	Looper (left hand) Driving Shaft	F6
108919	Looper (right hand) Driving Shaft with 106494	F6
109329(803)	Machine Frame Rotary Shaft Ball Bearing Housing Screw (4)	J3
109795(803)	Looper (right hand) Carrier Connecting Link Adjusting Screw (front)	F6
109876	Needle Driving Shaft Bushing Locating Screw	E5
109898(832)	Presser Bar Lifting Lever Stop Screw	B3
109927(869)	Looper (right hand) Carrier Connecting Link Hinge Pin Set Screw (2)	F6
109927(869)	Thread (looper) Plate Cover Hinge Pin Locking Screw	J8
109927(869)	Chain Cutter Knife (movable) Driving Fork Set Screw (2)	M1
109927(869)	Chain Cutter Knife (movable) Driving Slide Block Stud Set Screw	C6
113176	Knife (stationary) and Needle Guard Holder Sleeve Stud Lock Nut	D6
113176(850)	Knife (movable) Lever and Presser Bar (upright) Housing Cover Spring Pin Lock Nut	E4
113177	Machine Frame Rotary Shaft Nut	A7
113177	Oil Pump Relief Valve Spring Screw Stud Locking Nut	E4
113180(429)	Tension (heavy) Regulating Thumb Nut (green)	E1
113180(431)	Tension (heavy) Regulating Thumb Nut (red)	E1
113180(430)	Tension (light) Regulating Thumb Nut (yellow)	E1
113191(888)	Tension (heavy) Regulating Thumb Nut Lock Nut	E1
113191(888)	Tension (light) Regulating Thumb Nut Lock Nut	E1
113330	Knife (movable) Lever and Presser Bar (upright) Housing Cover Hinge Bracket Centre Screw Lock Nut (2)	B4, C3
114032(832)	Knife (stationary) Clamping Gib Screw	D6
114036	Looper (right hand) Four-bar Linkage Mechanism Stabiliser Securing Screw	F5
114038(809)	Oil Pump Body Clamping Screw Hole Plug Screw	G5
114071(819)	Feed Eccentric Cover Hinge Screw	A7
114077	Machine Frame Rotary Shaft Screw Stud	H2
114081	Oil Pump Relief Valve Spring Screw Stud	E4
114082(819)	Knife (movable) Lever and Presser Bar (upright) Housing Cover Stop Plate Screw	D3

PART No.	DESCRIPTION	LOCATION
114082	Presser Bar (swing-out) Opening Lever Hinge Screw	C4
114091(869)	Needle Driving Shaft Crank Screw	—
114092(803)	Looper (left hand) Driving Shaft Crank Clamping Screw	—
114092(803)	Looper (right hand) Driving Shaft Crank Clamping Screw	—
114117(803)	Tension (heavy) Screw Stud	E2
114117(803)	Tension (light) Screw Stud	E2
114130	Knife (stationary) and Needle Guard Holder Sleeve Stud Set Screw	D7
114133(869)	Needle Driving Shaft Crank Position Screw	E5
114134(869)	Chip Chute Support Plate Screw (2)	L8
114142(809)	Belt Cover Screw (2)	H1, J2
114159	Pressure Regulating Thumb Screw Lock Screw	C4
114224(869)	Cloth Plate Position Collar Set Screw (2)	A6
114224(869)	Looper (left hand) Set Screw (2)	G6
114224(869)	Oil Pump Suction Filter Collar Securing Screw	F6
114246(809)	Cloth Plate Position Bracket Screw	B6
114246(809)	Feed Eccentric Cover Positioning Screw	L3
114256-451	Looper (left hand) Carrier Holder Clamping Screw	G7
114256-451	Looper (right hand) Driving Lever Clamping Screw	F6
114258-451	Looper (left hand) Driving Shaft Crank Connection Cap (upper) Screw	—
114258-451	Looper (right hand) Driving Shaft Crank Connection Cap (upper) Screw	—
114263-451	Looper (left hand) Driving Shaft Crank Connection Cap (lower) Screw	—
114263-451	Looper (right hand) Driving Shaft Crank Connection Cap (lower) Screw	—
114264-451	Needle Driving Shaft Crank Connection Cap (lower) Screw	—
114275(888)	Pressure Regulating Thumb Screw	C3
114278	Knife (movable) Lever and Presser Bar (upright) Housing Cover Hinge Bracket Cutter Screw	B4, C3
114285(869)	Thread Eyelet (needle thread) Bridge Tube Securing Screw	D5
114287(805)	Presser Bar Lifter Operating Arm Bracket Bolt	L8
114290(809)	Oil Pump Suction Pipe Securing Screw	G4
115007	Machine Frame Rotary Shaft Key	D5
115090	Presser Bar Lifter Connecting Cable	M8
115140	Knife (stationary) and Needle Guard Holder	D6
115141	Knife (stationary) and Needle Guard Holder (adjustable) complete Nos. 141444(831), 164745 and 115140	D7
115142	Knife (stationary) and Needle Guard Holder (adjustable) with Gib complete Nos. 164744, 115141 and 114032(832)	D7
115143	Oil Pipe Guide Pin	E5
115143	Thread (looper) Plate Cover Latch Spring Pin	J7
115227	Chain Cutter Knife (movable) Shaft Drive Collar with three 141087(869)	M2
115228	Chain Cutter Knife (movable) with 115240	M2
115240	Chain Cutter Knife (movable) Drive Pin	M2
115331	Chain Cutter Knife (movable) Shaft	L1
115332	Chain Cutter Knife (stationary)	M1
115333	Chain Cutter Knife (stationary) Extension	M1
115417	Chip Guard complete	G7
115418	Treadle Extension	K8
115420	Treadle 152168 with 51723, 115418, 152171 and 67425	—
115421	Treadle 115420 with 152153 and two 152080	—
115440	Looper (right hand) Carrier Connecting Link Eccentric Adjusting Sleeve Cap Plug	F6
115441	Looper (right hand) Four-bar Linkage Mechanism complete Nos. 1700(809), 109795(803), 115440, 164068, two each 1209(830) and 132584	F6
115465	Machine Base	K6
115466	Oil Reservoir	E7
115484	Tension Thread Guide	D1
115487	Machine Frame Top Cover Closing Plate with 107044	E3
115491	Chip Chute Sleeve	M7
115492	Chip Chute	M8
115496	Knife (movable) Lever and Presser Bar (upright) Housing Cover (hinged)	D3
115499	Machine Frame Top Cover with 108300, 228661 and two 107090	E2
115501	Feed Eccentric Cover	B7
115503	Knife (movable) Lever and Presser Bar (upright) Housing Cover Stop Plate	D3
115508	Needle Driving Shaft Assembly	D5
115510	Oil Reservoir Gasket	E7
115514	Oil Breather Plug Screw	E4
115515	Cloth Plate	A5
115517	Oil Filler Cap and Flow Indicator	E3
115518	Chip Chute Support Plate	L7
115519	Machine Frame Support Pin	E7
115520	Presser Bar Lifting Lever (long)	A4
115523	Knife (movable) Lever and Presser Bar (upright) Housing Cover Hinge Bracket	B4
115529	Feed Eccentric Cover	—
115534	Oil Pump Suction Pipe	G4
115536	Oil Pump Suction Filter Cap	F6
115538	Oil Pump Suction Pipe Gasket	G4
115540	Oil Filler Cap Oil Seal	E3
115541	Tension Regulator Thread Guide	E2
115544	Presser Bar Lifting Lever (long) Connection Rod	A3

PART No.	DESCRIPTION	LOCATION
115545	Thread (needle) Guide Post	E2
115555	Cloth Plate Lock Spring	B6
115571	Cloth Plate Lock Spring Retaining Screw Stud	D8
115572	Oil Pipe	E4, E5
115586	Cloth Plate 115515 with 1700(809), 114246, 115555 and two 237(809)	A5
115587	Machine Frame Top Cover Assembly Nos. 1607(809), 107085(429), 107085(431), 107086(430), 108300, 108864, 115484, 115545, 226661, two 1628(809), 98188, 107090, three 1698(809), 115541 and 931084	F3
115589	Oil Reservoir 115466 with 107071, 107204 and 106401	F7
115590	Thread (looper) Plate Cover with 109927(869)	J7
115591	Thread (looper) Plate Cover 115590 with 107095, 107096, 107097 and 1094(819)	H8
115598	Machine Frame Handle	A8
115608	Thread Unwinder (three spools) complete	M5
115673	Machine Frame Oil Splash Guard (top)	B5
115674	Cover Latch Spring Screw Holder Washer	E3
115679	Thread Eyelet (needle thread) Bridge complete Nos. 108785, 108484, 108330 and two 208(829)	D4
115684	Screw Driver	L5
115699	Machine Frame Rotary Shaft complete Nos. 113177, 115007, two 98930 and three 107037	E5
115727	Cloth Plate with 165507	L2
115728	Cloth Plate 115727 with 1700(809), 114246(809) and two 237(809)	L2
115730	Thread (looper) Plate Cover with 109927(869)	—
115731	Thread (looper) Plate Cover 115730 with 107095, 107096, 107097 and 1094(819)	—
115739	Oil Pipe Banjo Connection (2)	F4, E6
115740	Oil Pipe Banjo Connection Washer (fibre) (4)	F4, E5, E8
115741	Oil Pipe Banjo Connection Retaining Screw	F4
115742	Oil Pipe Banjo Connection Retaining Screw (lower)	E6
115814	Oil Pipe 115572 with two 90100 and 115739	E6
115841	Presser Bar Lifter Operating Arm 108222 with 114287(805), 98188, 1654, 115090 and two 8905	—
125399	Cloth Plate Hinge Stud Friction Washer	A6
132584	Looper (right hand) Carrier Connecting Link Hinge Pin Oil Wick (2)	F6
139026	Machine Frame Rotary Shaft Ball Bearing	H3
140050(833)	Knife (movable) Clamp Screw	D6
140393(830)	Looper (left hand) Carrier Holder Set Screw (right)	G6
140393	Foot Lifter Operating Cable Retaining Collar Screw	K8
140416(853)	Machine Pulley Cap Screw	J1
140509(809)	Chip Guard Screw (upper)	H7
140510(819)	Presser Bar (swing-out) Pivot Screw	C5
140596(830)	Looper (left hand) Carrier Holder Set Screw (left)	G7
140930(869)	Looper (left hand) Driving Shaft Crank Position Screw	E5
140930(869)	Looper (right hand) Driving Shaft Crank Position Screw	E5
141004(830)	Knife (stationary) and Needle Guard Holder Locking Screw	C7
141087(869)	Chain Cutter Knife (movable) Drive Pin Securing Screw	M2
141087(869)	Chain Cutter Knife (movable) Shaft Drive Collar Set Screw (2)	M2
141228-002	Treadle Hinge Bracket Bolt	L8
141292(869)	Knife (movable) Lever Hinge Pin Set Screw (2)	C5
141292(869)	Looper (left hand) Carrier Set Screw	G6
141444(831)	Knife (stationary) and Needle Guard Holder Screw	C7
141575	Feed Eccentric Cover Positioning Screw	B7
149224	Oil Return Filter (front) Pad	E7
152080	Treadle Position Collar with 51089	K8
152153	Treadle Spring	L8
152168	Treadle	K8
152171	Treadle Extension Swivel Stud	K7
161294	Screw Driver (plastic handle) (large)	K5
164004	Feed Bar Slide Block (back) (2)	B6
164006	Feed (front) Bar with 164010	B6
164009	Feed (back) Bar Connection Hinge Screw Stud	B7
164009	Feed (front) Bar Connection Hinge Screw Stud	B6
164010	Feed (back) Bar Connection Hinge Screw Stud Position Pin	B7
164010	Feed (front) Bar Connection Hinge Screw Stud Position Pin	B6
164011	Feed (back) Dog Section (left)	—
164012	Feed (back) Dog Section (right)	—
164013	Feed (back) Dog complete Nos. 1100(830), 164011 and 164012 (standard for NAIMO)	—
164018	Feed (front) Bar Connection Bearing	A7
164019	Feed (front) Dog	C6
164027(819)	Knife (movable) Clamp	D6
164030	Knife (movable) Holder Screw Bearing	D6
164042	Foot Lifter Operating Cable Friction Sleeve	K7
164043	Knife (stationary) and Needle Guard Holder Spring	D7
164046	Looper (left hand) Carrier with 141292(869), 114224(809) and 164202	H5, G6
164053	Looper (left hand) Driving Shaft Crank Thrust Bearing	E5
164053	Looper (right hand) Driving Shaft Crank Thrust Bearing	E5
164053	Needle Driving Shaft Bushing Thrust Washer	E5

PART No.	DESCRIPTION	LOCATION
164068	Looper (right hand) Locking Screw Stud	F6
164091	Thread (looper right hand) Take-up with 164555	G7
164093	Machine Frame Rotary Shaft Ball Sleeve	—
164098	Machine Frame Rotary Shaft Oil Return and Ball Bearing Grease Retainer	H3
164100	Machine Frame Rotary Shaft Thrust Bearing	H3
164139	Presser Bar Lifting Lever Spring	B3
164141(850)	Presser Bar (swing-out) Lifting Screw Stud	C5
164143(850)	Presser Bar (upright)	C5
164144	Presser Bar (upright) Spring (alternative to 164416)	—
164145	Presser Foot Body (for 164150)	—
164146	Presser Foot Chaining-off Finger	—
164147	Presser Foot Clamping Plate	—
164149	Presser Foot Guide	—
164150	Presser Foot complete 50169(809), 50225(809), 51306(805), 164145, 164146, 164147, 164149, 164220 and 164221 (standard for NAIMO)	—
164157	Tension (light) Spring	E1
164163	Thread (looper right hand) Take-up Eyelet (adjustable)	H7
164164	Thread Take-up (adjustable) (accessory)	K5
164165	Thread (looper right hand) Thread Eyelet (stationary)	H7
164173	Thread (looper) Plate Thread Bushing	H7
164176	Thread (looper right hand) Take-up Plate	G7
164189	Machine Cushion (small)	K6
164196	Threader (6)	K6
164202	Looper (left hand) Stop Pin	G6
164203	Feed Eccentric Extractor	K5
164220	Presser Foot Chain Cutter Friction Plate	—
164221	Presser Foot Chain Cutter Knife	—
164351(819)	Presser Bar (swing-out) Pivot Screw Locking Plate	C6
164416	Presser Bar (upright) Spring (heavy)	C4
164449	Thread (looper right hand) Thread Eyelet (movable)	H7
164525	Knife (stationary) and Needle Guard Holder Spring Stud	D6
164550	Knife (movable)	K5, D6
164555	Thread (looper right hand) Take-up Guide Wire	H7
164660	Looper (left hand) Carrier Holder with 114256-451, 140393(830) and 140596(830)	G6, H6
164661	Looper (left hand) Carrier Holder 164660 with 1324(803), 59456 and 164046	H6
164687	Feed (back) Bar with 164010	B7
164727	Knee Lifter complete	L7
164728	Knife (stationary)	K5, D6
164744	Knife (stationary) Clamping Gib	D6
164745	Knife (stationary) and Needle Guard Holder Body with two 50811(803)	C7
165058	Needle Guard	C7
165059(813)	Needle Guard Holder	C7
165135	Feed Bar Slide Block (front)	B7
165157	Oil Return Filter (front) Fastener	E7
165290	Cloth Plate Position Collar with two 114224(869)	A6
165291	Knife (movable) Guard (lower)	D6
165384	Machine Frame Oil Drain Plate Screen	D6
165395	Machine Frame Oil Drain Plate	D7
165406	Machine Frame Wearing Plate	E6
165487	Knife (movable) Guard (upper)	D6
165519	Machine Frame Oil Drain Plate Filter (felt)	D7
175032(819)	Feed Bar Guide Screw Washer (2)	A7
175032(819)	Thread (looper) Plate Cover Hinge Bracket Screw Washer (2)	J8
228661	Machine Frame Top Cover Tension Screw Hole Plug	H6
228661	Thread (looper) Plate Cover Stop (rubber) (2)	H8
271779	Cloth Plate Lock Spring Retaining Screw Stud Sleeve	D8
350647(869)	Oil Pump Body Clamping Screw	G4
350647(869)	Machine Base Mounting Screw (4)	L9
350680	Looper (right hand) Four-bar Linkage Mechanism Stabiliser Screw	F5
350719(869)	Needle Carrier Clamping Screw	D5
350719(869)	Oil Pump Cover Screw (3)	H3
350744(869)	Machine Frame Bracket Screw	—
350744	Oil Reservoir Screw (6)	D8, F8
350754(869)	Knife (movable) Lever and Presser Bar (upright) Housing Cover Hinge Bracket	B3
350781(869)	Machine Frame Oil Plug Bracket Set Screw	C7
701679	Earthing Wire Screw Washer	M8
820193-002	Wrench (regular) for 1/16 in Socket Head Screw	L5
820193-003	Wrench (regular) for 5/64 in Socket Head Screw	L5
820193-005	Wrench (regular) for 1/8 in Socket Head Screw	L5
820193-007	Wrench (regular) for 3/16 in Socket Head Screw	L5
820193-009	Wrench (long) for 3/32 in Socket Head Screw	L5
820193-010	Wrench (regular) for 7/32 in Socket Head Screw (2)	L5
931084	Tension (heavy) Screw Stud Washer	E2
931084	Tension (light) Screw Stud Washer	E1
Cat. 1431	Needle Size 32	D6

PART No.	DESCRIPTION	LOCATION
176(809)	Earthing Wire Screw	M8
187(805)	Machine Frame Bracket Key Screw	—
187(805)	Thread (looper right hand) Take-up Screw	H7
190(805)	Thread (looper) Take-up Screw (lower)	G7
198(819)	Knife (movable) Holder Screw	D6
208(829)	Thread Eyelet (needle thread) Bridge Tube Support Securing Screw (2)	D5
225(819)	Looper (right hand) Carrier Connecting Link Adjusting Sleeve Wick Clip Screw	E6
225(806)	Machine Frame Closing Plate Screw (3)	E6
225(806)	Oil Deflector Screw	E6
227(809)	Feed Eccentric Cover Latch Spring Screw	B8
227(819)	Knife (movable) Lever and Presser Bar (upright) Housing Cover Latch Spring Screw	E3
237(809)	Cloth Plate Lock Spring Screw (2)	B6
339(830)	Thread (needle) Controller Screw (2)	D5
440(830)	Knife (movable) Lever Hinge Stud Set Screw (top)	C6
447(830)	Knife (movable) Lever Bearing Set Screw (long)	D5
447(830)	Knife (movable) Lever Guide Set Screw	D5
447(830)	Knife (movable) Lever Hinge Stud Set Screw (back)	C6
448(830)	Machine Pulley Set Screw (2)	H2
448(830)	Oil Pump Body Bushing and Machine Frame Rotary Shaft (intermediate) Bushing Set Screw	G4
460(830)	Thread Eyelet (needle thread) Set Screw	C4
462(830)	Presser Bar Lifting Bracket Set Screw (short)	C4
462(830)	Thread (looper right hand) Tube (lower) Set Screw	H7
624(830)	Knife (movable) Lever Bearing Set Screw (short)	D5
624(830)	Presser Bar Lifting Bracket Set Screw (long)	C4
691(803)	Machine Frame Wearing Plate Screw (2)	E6
853(830)	Looper (left hand) Thread Tube (lower) Set Screw	C7
1083(805)	Needle Guard Holder Screw	C7
1094(850)	Machine Frame Top Cover Closing Plate Screw (8)	E3
1094(809)	Presser Bar Lifting Lever (long) Tension Spring Securing Screw	A4
1094(819)	Thread (looper) Plate Cover Latch Spring Screw	J7
1094(806)	Throat Plate Screw (2)	C6
1100(830)	Feed (back) Dog Section (right) Screw	—
1209(809)	Chip Guard Screw (lower)	G8
1209(809)	Cloth Plate Hinge Stud Washer Retaining Screw	A6
1209(830)	Looper (right hand) Driving Lever Clamping Screw (2)	F6
1209(819)	Thread (looper) Plate Cover Hinge Bracket Screw (2)	J8
1209(809)	Machine Frame Handle Screw (2)	A8
1231(819)	Machine Frame Oil Splash Guard (top) Screw (2)	B5
1239(819)	Thread (looper) Plate Screw (2)	H7
1250	Feed Eccentric Cover Latch Spring Retaining Screw Stud	B8
1259(830)	Knife (movable) Lever Bearing and Attachment Bracket Screw	D5
1324(830)	Feed Bar Guide Screw (2)	A6
1324(803)	Looper (left hand) Carrier Screw	G6
1329(805)	Chain Cutter Knife (stationary) Extension Screw (2)	M2
1329(805)	Chain Cutter Knife (stationary) Screw	M1
1389(830)	Feed Bar Hinge Pin Set Screw	A7
1423(809)	Thread Eyelet (needle thread) Bridge Securing Screw	D5
1423(809)	Thread (looper right hand) Thread Eyelet (movable) Screw	J7
1443(813)	Feed Eccentric Oil Cover Screw	A7
1443(809)	Thread (looper right hand) Take-up Eyelet (adjustable) Screw	H7
1454(806)	Feed (back) Dog Screw	B6
1454(806)	Feed (front) Dog Screw	B7
1454(805)	Machine Frame Oil Drain Plate Screw (2)	D7
1607(809)	Thread (looper right hand) Thread Eyelet (stationary) Nut	H7
1607(809)	Thread (needle) Guide Post Securing Nut	E3
1628(809)	Knife (movable) Lever Hinge Pin Bearing Lock Nut	C6
1628(809)	Tension Thread Guide Securing Nut	E2
1637(810)	Presser Bar Lifting Lever Stop Screw Nut	B3
1654	Presser Bar Lifter Operating Arm Bracket Bolt Nut	M8
1698(809)	Tension (light) Screw Stud Nut	E2
1698(809)	Tension (heavy) Screw Stud Nut	E3
1700(819)	Cloth Plate Position Bracket Screw Nut	B6
1700(819)	Feed Eccentric Cover Positioning Screw Lock Nut	B7
1700(809)	Looper (right hand) Locking Screw Stud Nut	F6
1700(809)	Oil Deflector Screw Nut	E6
1700(819)	Presser Bar (swing-out) Lifting Screw Stud Nut	C6
1718(803)	Feed (back) Bar Connection Hinge Screw Stud Nut	A7
1718(803)	Feed (front) Bar Connection Hinge Screw Stud Nut	A7
2102	Tension (heavy) Disc	E1
2102	Tension (light) Disc	E1
8905	Presser Bar Lifter Operating Arm Bracket Washer	M8
9525(803)	Feed (back) Bar Connection Hinge Screw Stud Nut Washer	A7
9525(803)	Feed (front) Bar Connection Hinge Screw Stud Nut Washer	A7
9525(819)	Chip Chute Support Plate Screw Washer	L7
9842	Machine Base Mounting Screw Washer (4)	L8

SINGER

990_{E3} 990_{E43}

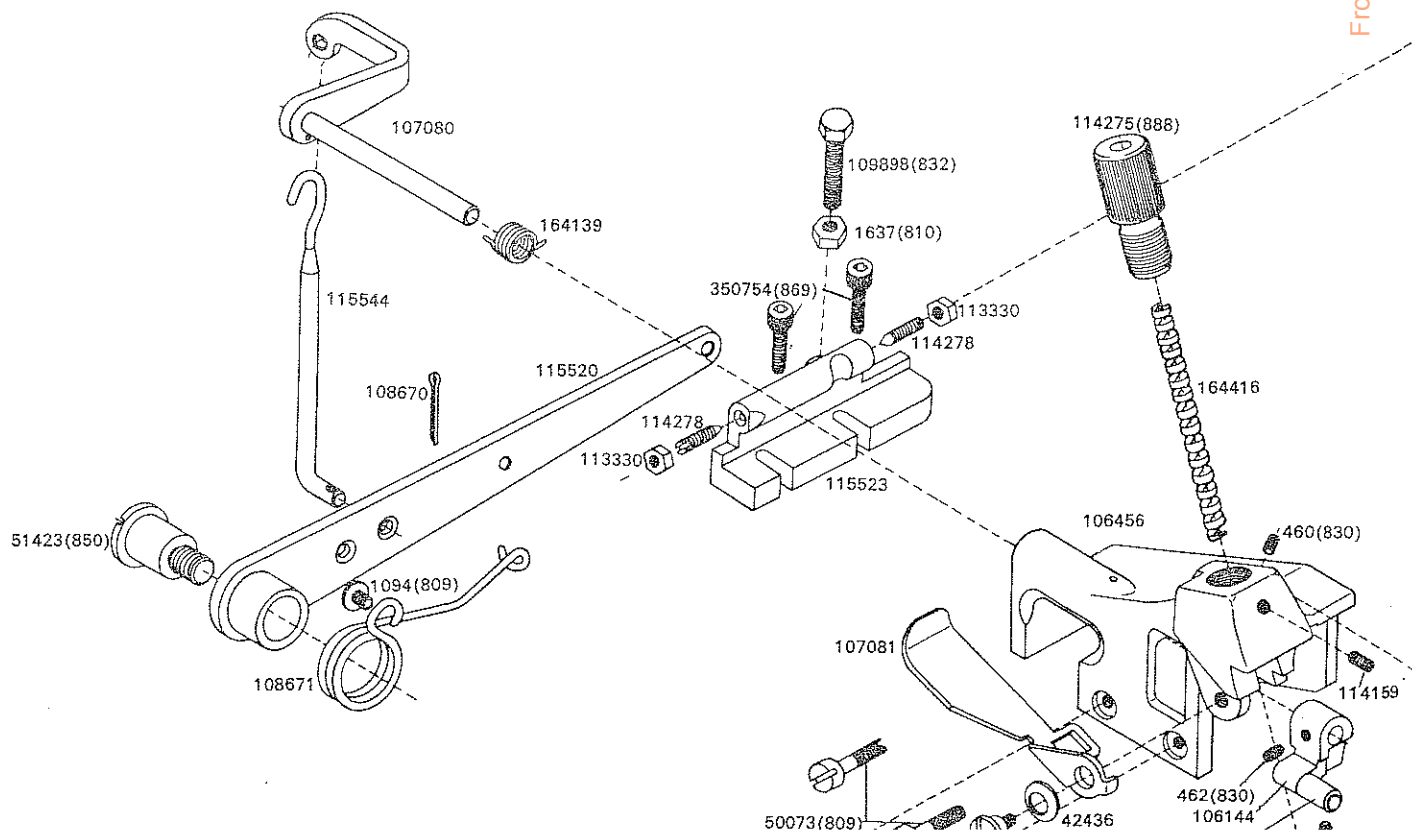

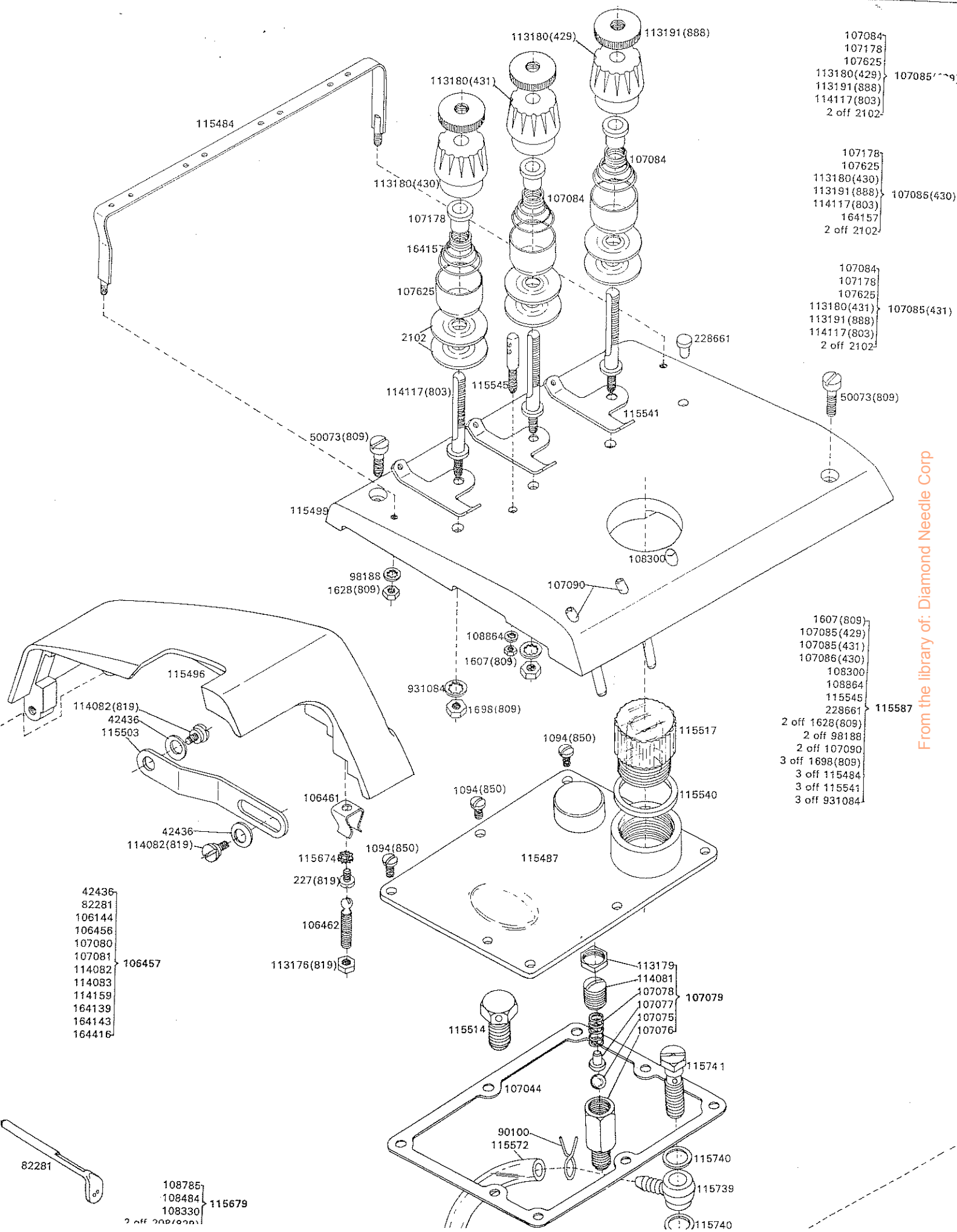

- 107084
- 107178
- 107625
- 113180(429)
- 113191(888)
- 114117(803)
- 2 off 2102

- 107178
- 107625
- 113180(430)
- 113191(888)
- 114117(803)
- 164157
- 2 off 2102

- 107084
- 107178
- 107625
- 113180(431)
- 113191(888)
- 114117(803)
- 2 off 2102

- 1607(809)
- 107085(429)
- 107085(431)
- 107085(430)
- 108300
- 108864
- 115545
- 228661
- 2 off 1628(809)
- 2 off 98188
- 2 off 107090
- 3 off 1698(809)
- 3 off 115484
- 3 off 115541
- 3 off 931084

- 42436
- 82281
- 106144
- 106456
- 107080
- 107081
- 114082
- 114083
- 114159
- 164139
- 164143
- 164416

- 108785
- 108484
- 108330
- 2 off 209(809)

From the library of: Diamond Needle Corp

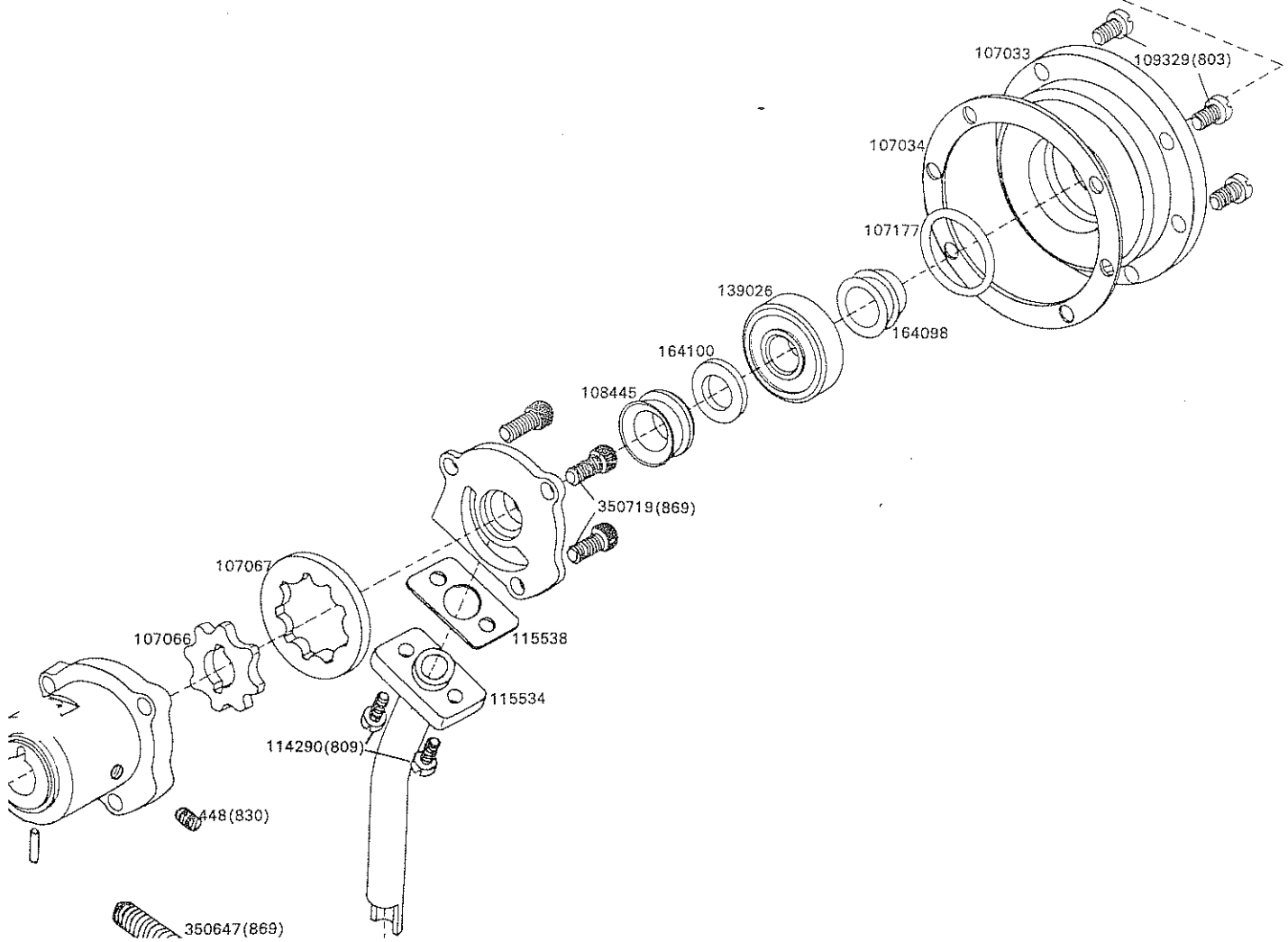
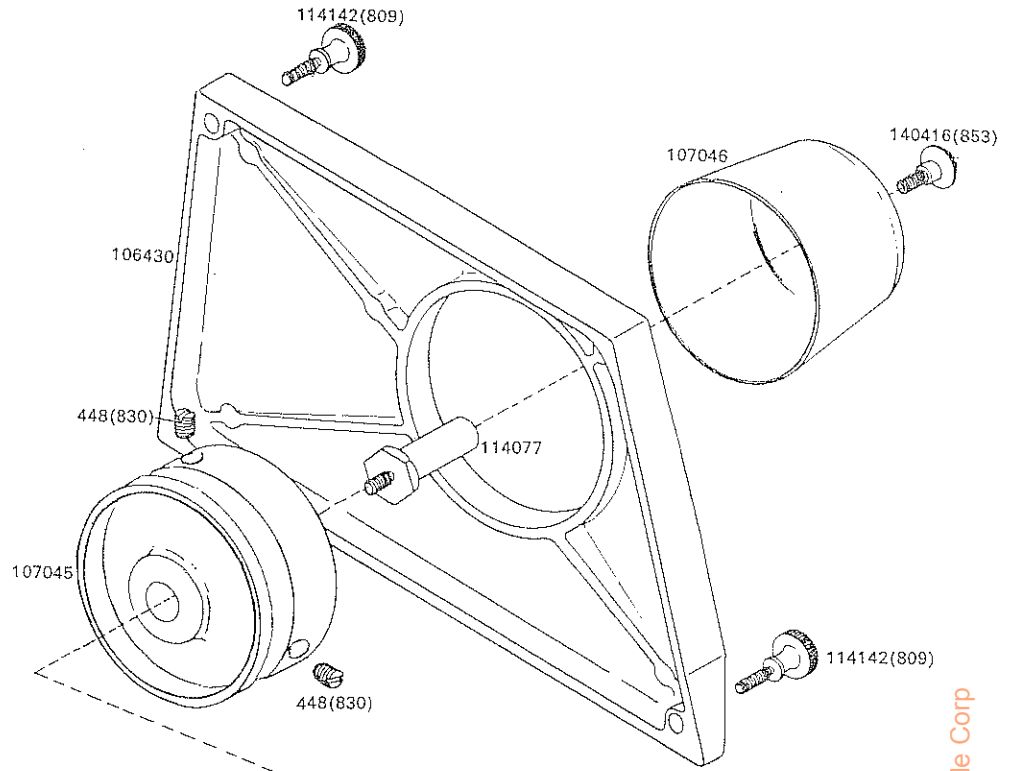

115515
 1700(809)
 114246(809) 115586
 115555
 2 off 237(809)

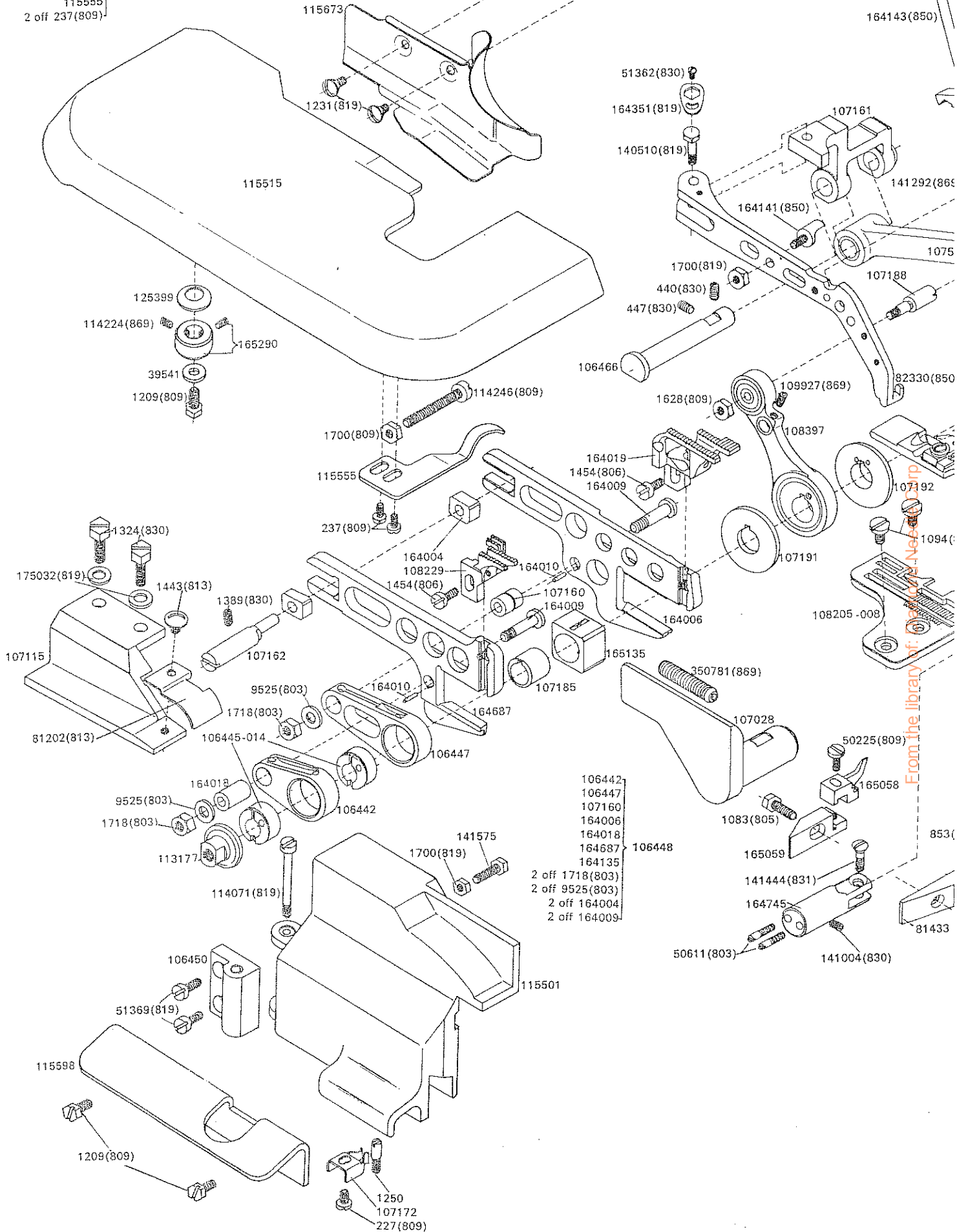

From the library of: www.mechassis.com

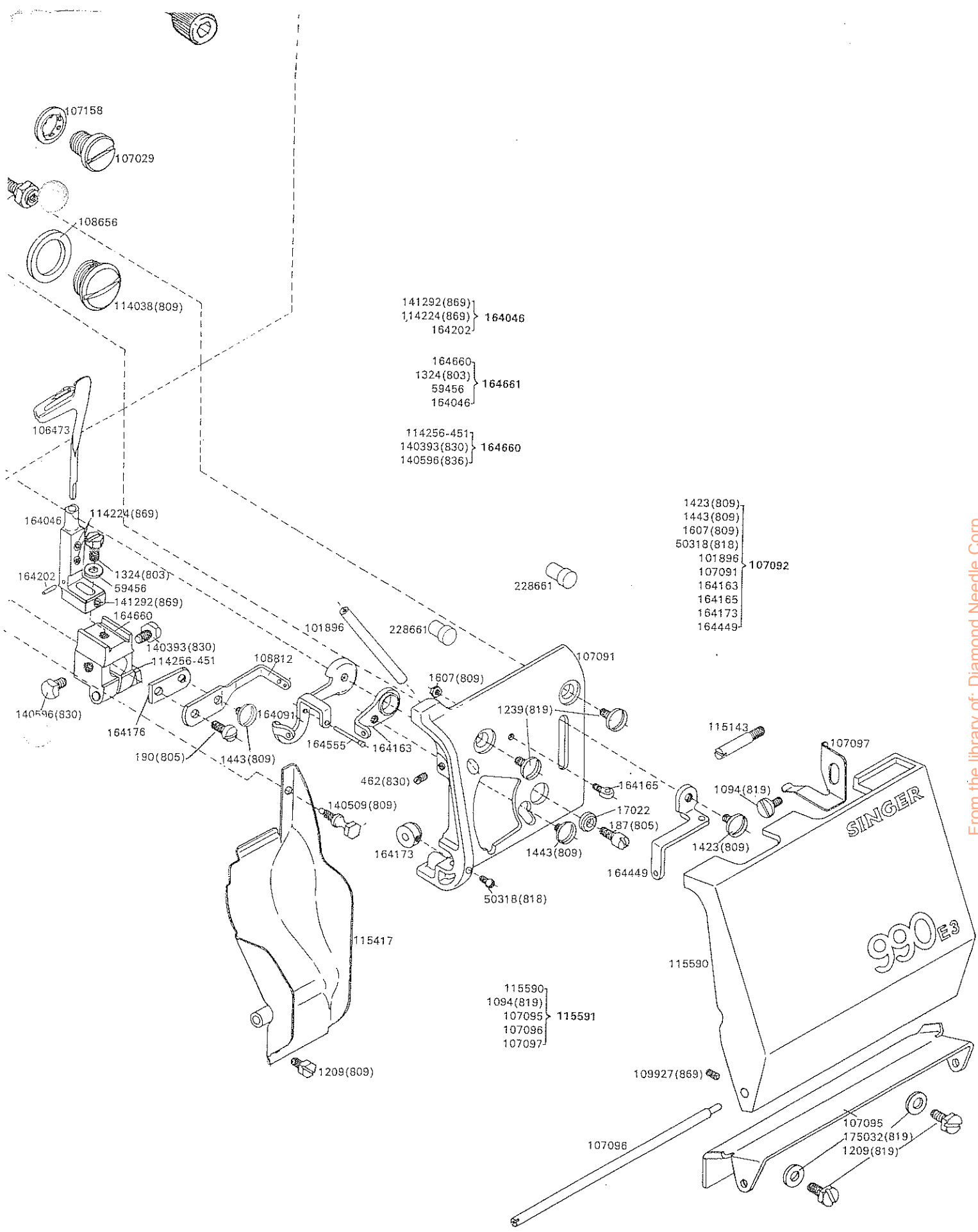

From the library of: Diamond Needle Corp

990 E43

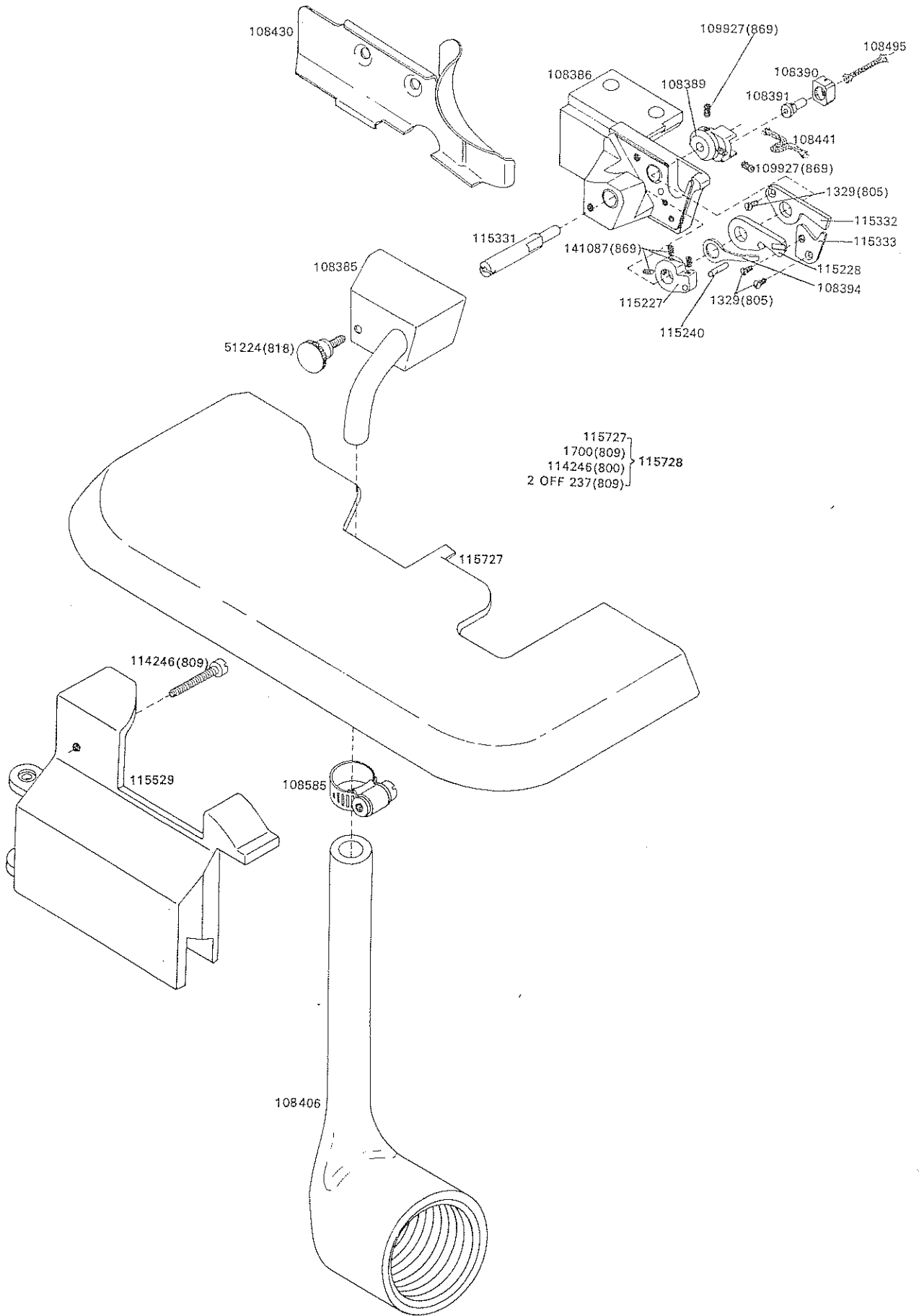

ACCESSORIES (NOT TO SCALE)

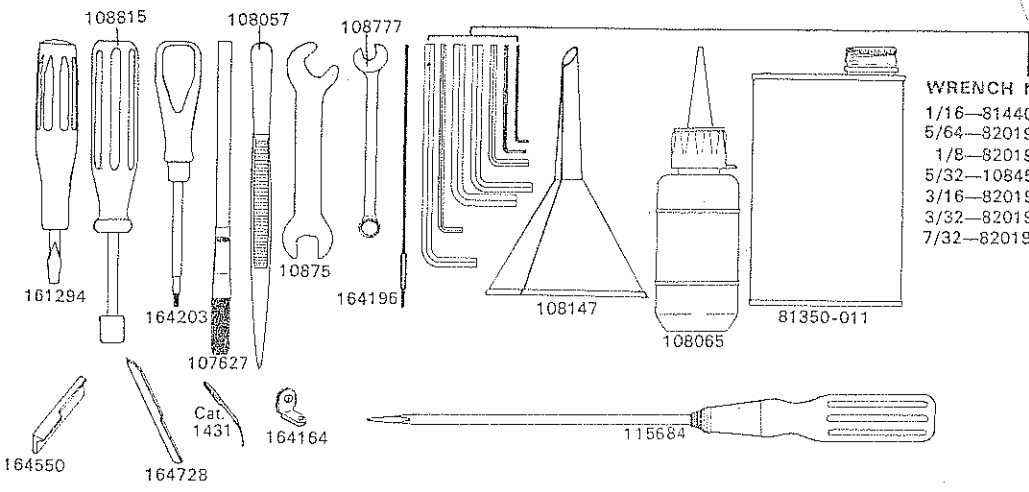

WRENCH NUMBERS

- 1/16—81440
- 5/64—820193-003
- 1/8—820193-005
- 5/32—108452
- 3/16—820193-007
- 3/32—820193-009
- 7/32—820193-010

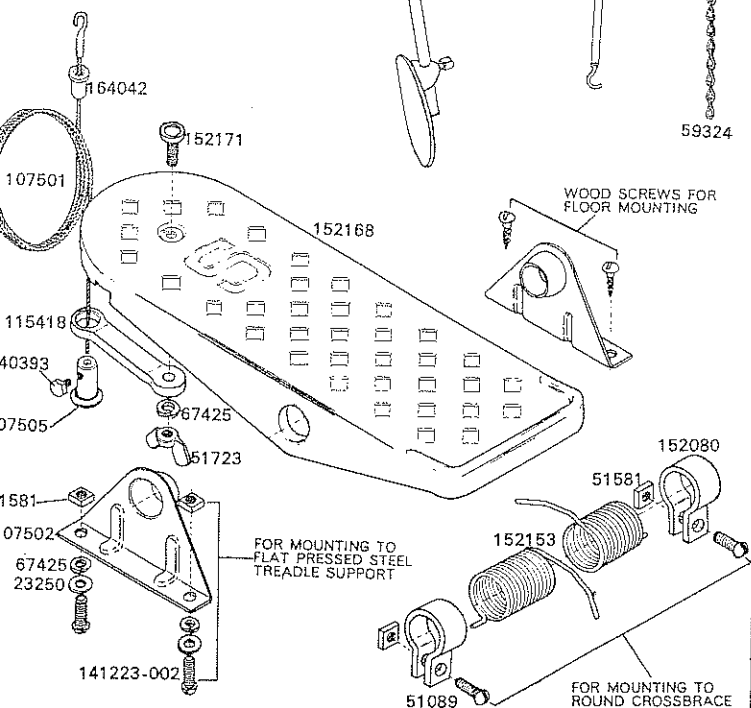
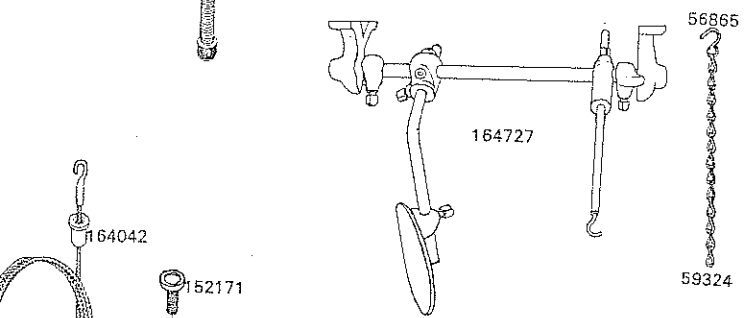
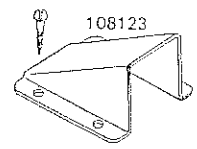
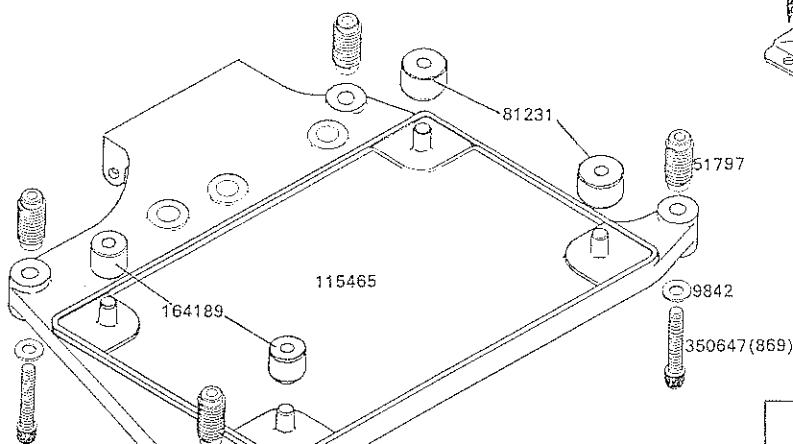
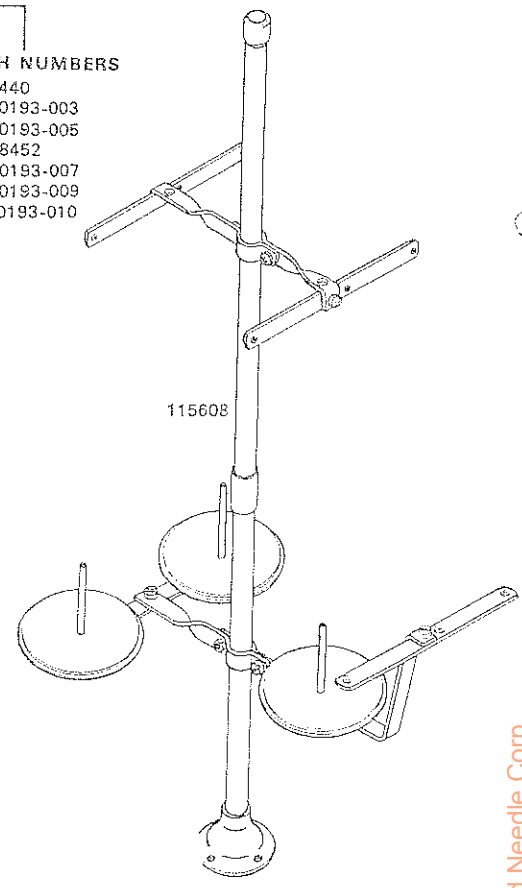

Available at an Extra Charge

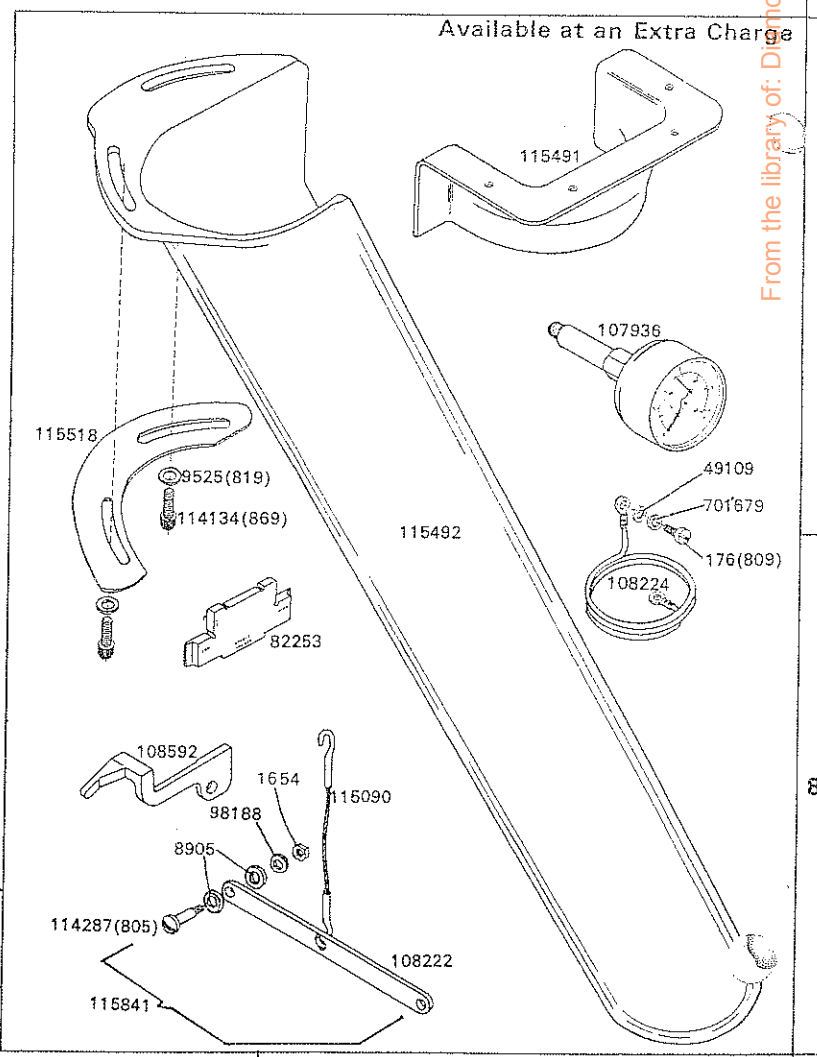

From the library of: Diamond Needle Corp

K

L

M